



RF

- STGRF6 STGRF6-SD
- STGRF9 STGRF6-SD
- STGRF12 STGRF12-SD
- STGRF15 STGRF15-SD

- Heated double glazed glass top, sides and front
- Heated rear sub frame
- Argon filled rear doors
- Sliding rear doors
- Solid front or sliding front doors
- Deck forced refrigeration
- Two adjustable shelves - flat or angled
- Ticket strips on shelves and base
- Under shelf and canopy LED lights
- Integral condenser

Solid glass front - optional
STGRF6 hinged rear door

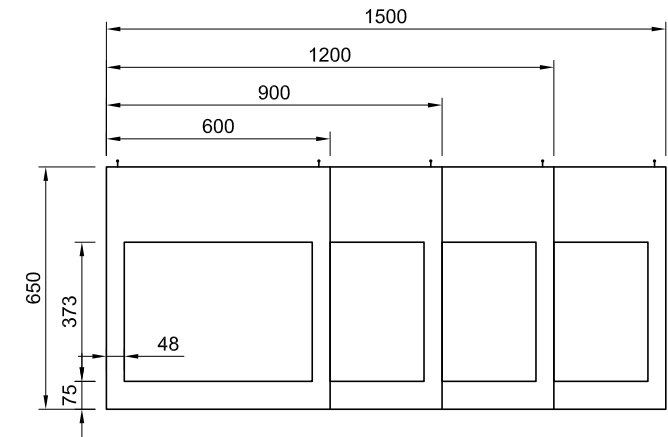
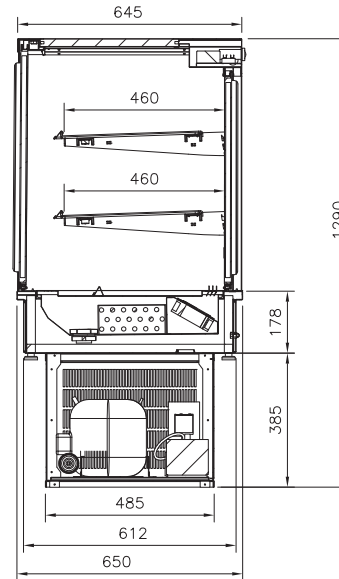

CABINET DIMENSIONS & SPECIFICATIONS

MODEL	CABINET			SHELVING WEIGHT KG	SHELVING 2 + BASE	OPERATING TEMP DEG C	SHELF W X D	BASE TRAY W X D	TOTAL FOOD 100MM UNITS	DISPLAY M ²	INTERNAL VOLUME M ³	FREQUENCY	REFRIGERANT	POWER		CONNECTION ELECTRICAL POWER CORD 2200MM		VOLTAGE	PACKED FOR SHIPPING			
	LENGTH [MM]	DEPTH [MM]	HEIGHT [MM]											KW 230V	AMP	NZ/AUS 10 AMP	UK 13 AMP		LENGTH [MM]	DEPTH [MM]	HEIGHT [MM]	WEIGHT
STGRF6 STGRF6-SD	600	650	925	143	2 + BASE	3-5	490 X 445	540 x 415	86	0.61	0.29	50/60 HZ	R290	1.01	4.3	3 PIN PLUG	3 PIN PLUG	220-240V	700	730	1450	150
STGRF9 STGRF9-SD	900	650	925	178	2 + BASE	3-5	790 X 445	840 x 415	136	0.96	0.45	50/60 HZ	R290	1.06	4.6	3 PIN PLUG	3 PIN PLUG	220-240V	1000	730	1450	185
STGRF12 STGRF12-SD	1200	650	925	212	2 + BASE	3-5	1090 X 445	1140 x 415	175	1.32	0.60	50/60 HZ	R290	1.15	5.0	3 PIN PLUG	3 PIN PLUG	220-240V	1300	730	1450	219
STGRF15 STGRF15-SD	1500	650	925	243	2 + BASE	3-5	1390 X 445	1440 x 415	285	1.67	0.75	50/60 HZ	R290	1.24	5.4	3 PIN PLUG	3 PIN PLUG	220-240V	1600	730	1450	300

Maximum shelf load weight 15kg spread evenly

SLIDING FRONT DOORS and rear glass sliding doors STGRF-SD
SOLID FRONT and rear glass sliding doors STGRF

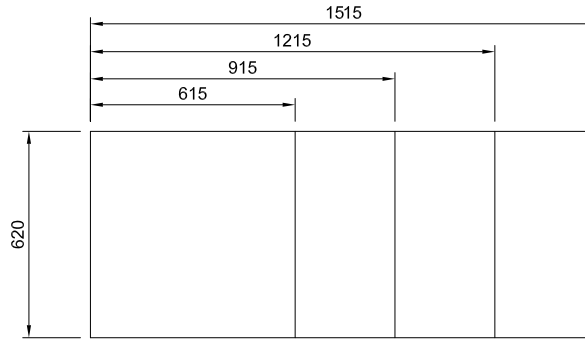

benchtop cut out sizes

Remove feet for all drop-in installations
Supplied 5mm PVC wedge strip to sides for drop-in unit.

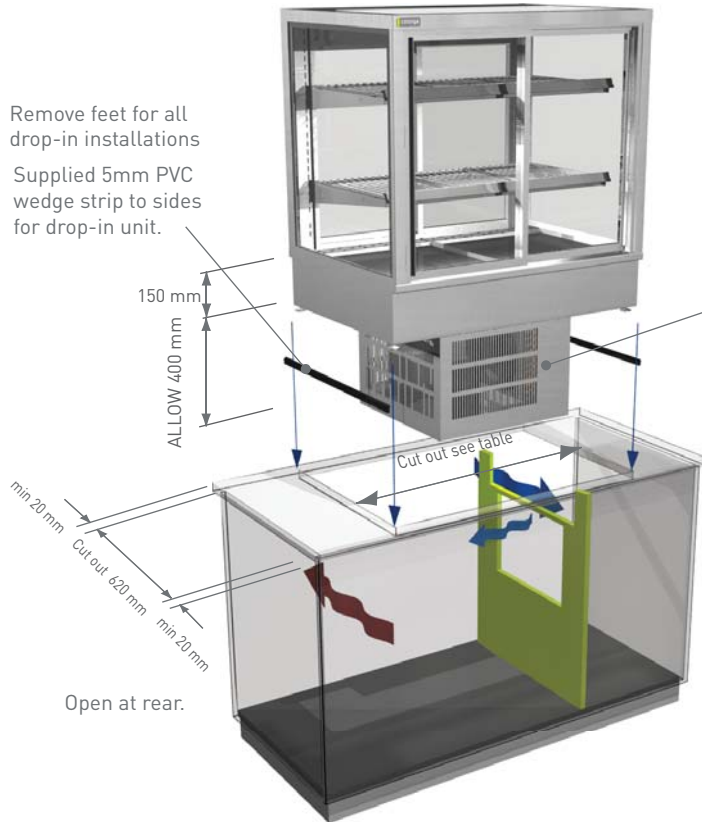

Full bench top drop in

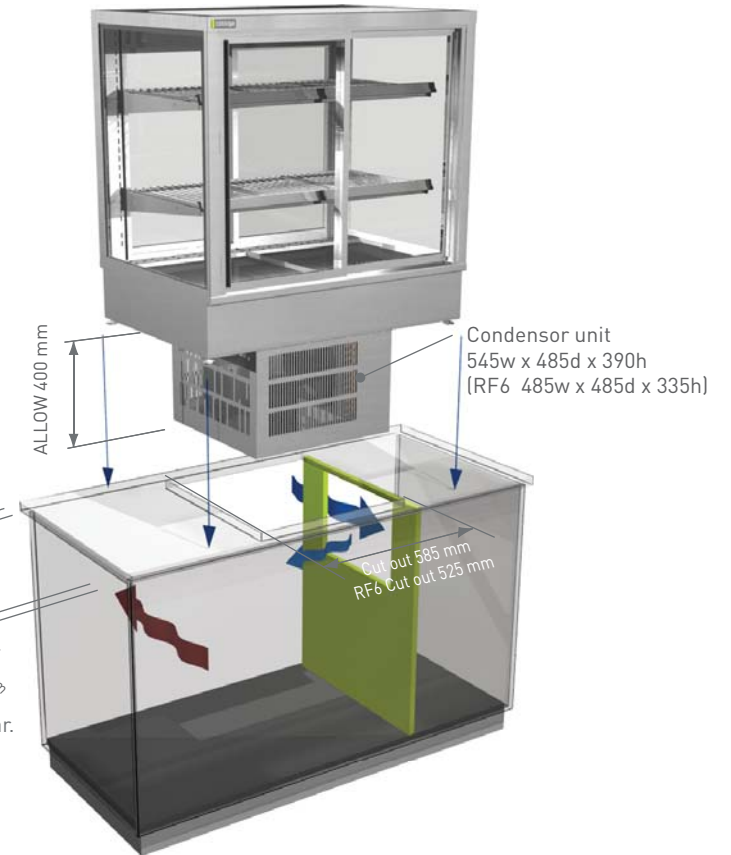

On bench top drop in

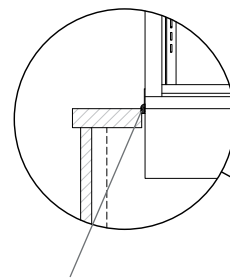

Supplied 5mm PVC wedge strip to sides for drop-in unit.
No glue or sealant required

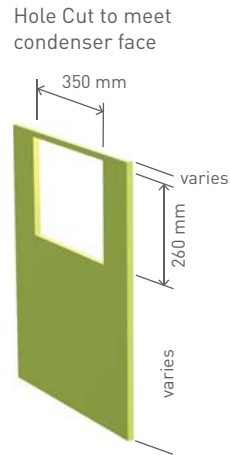
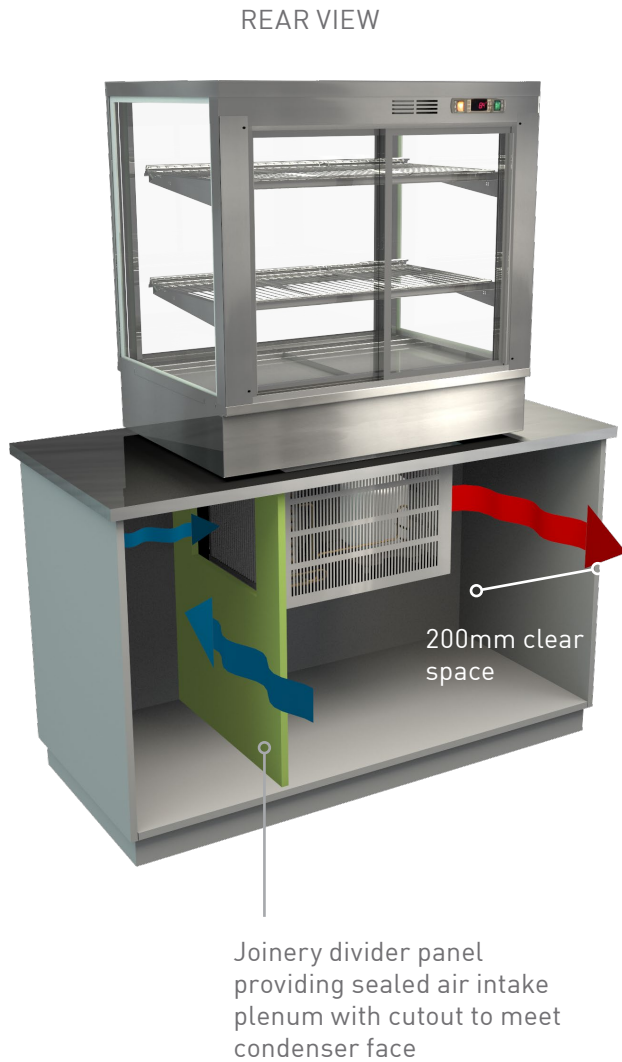

UNITS SHOWN FROM REAR VIEW



Ideal configuration cabinet open at rear

Cabinet with vented rear doors

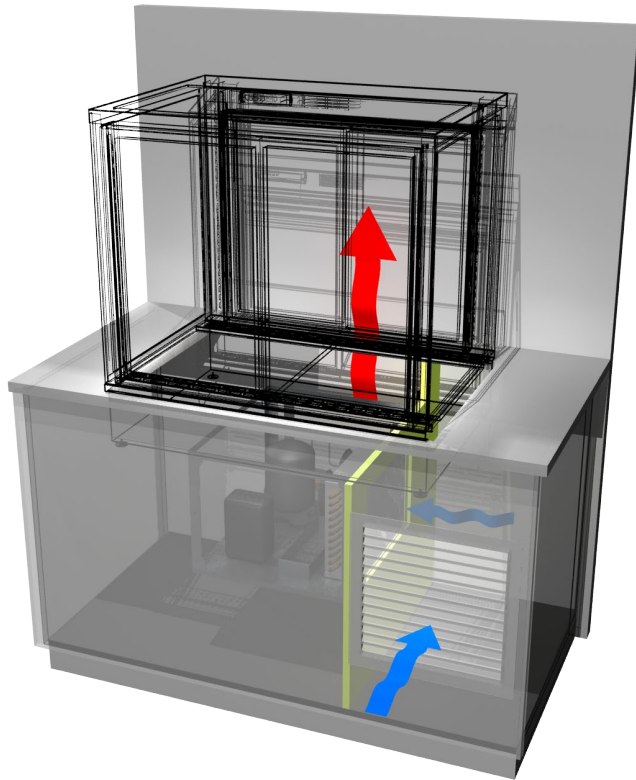

- Horizontal vent in cabinet top for hot air extract
- Electric biscuit fans can also be fitted to provide mechanical extract
- Ambient air ducted in to compressor face through air plenum space
- Joinery divider panel providing sealed air intake plenum with cut out to meet condensor face
- Allow access for cleaning, servicing and waste evaporator water removal

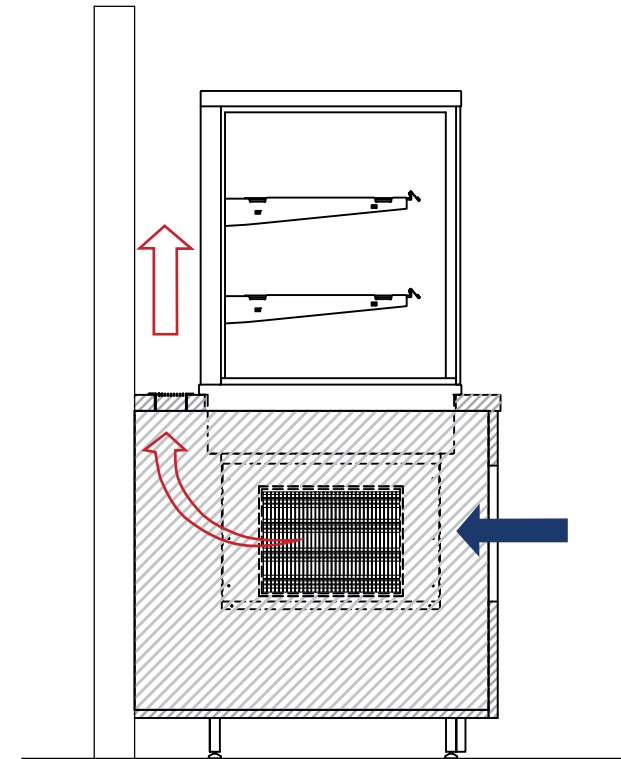

- Ambient air is drawn into front vented area
- Hot air must escape joinery cabinet
- A horizontal vent should be used behind the unit
Vent must be at least 100mm deep and as wide as unit

EXTRACTION FAN

- Extract hot air from box joinery
- Fan and power cable supplied, screw fixed to joinery
- Electrical power cord 2000mm 3 pin 10 amp 1 phase socket required
- Fan 230v ~ 50Hz - 60Hz - 19 Watt in stainless steel case
- Cossiga part number X000611 Extraction Fan

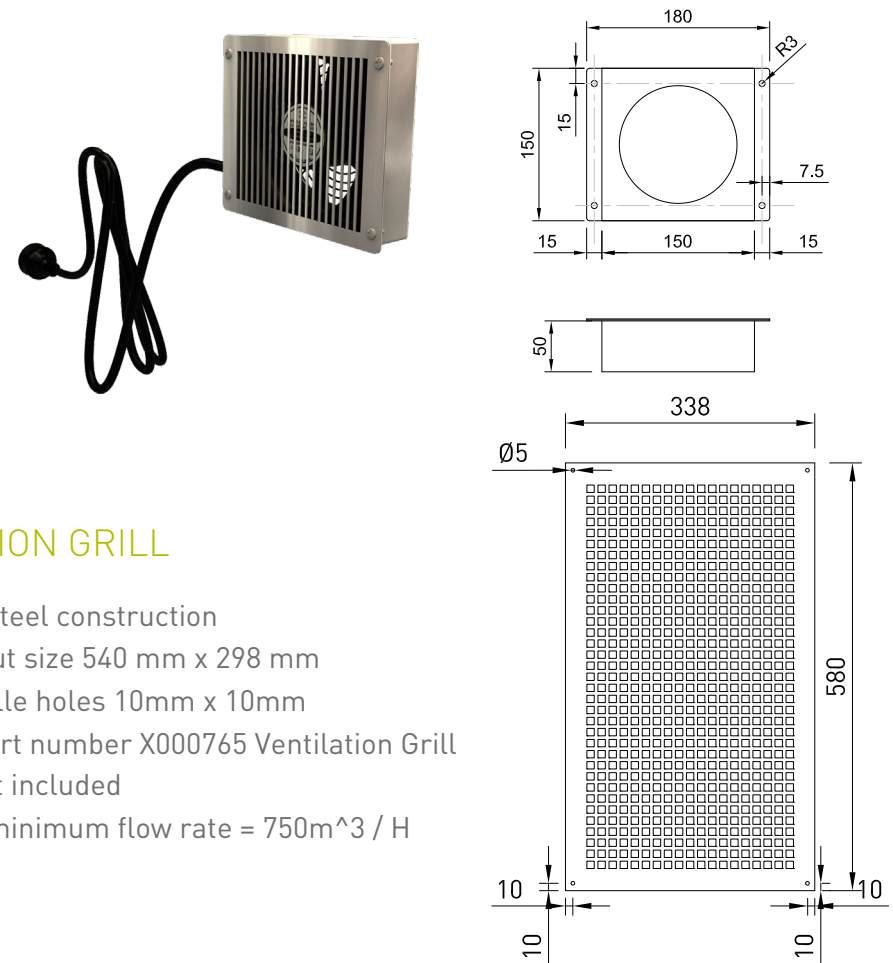
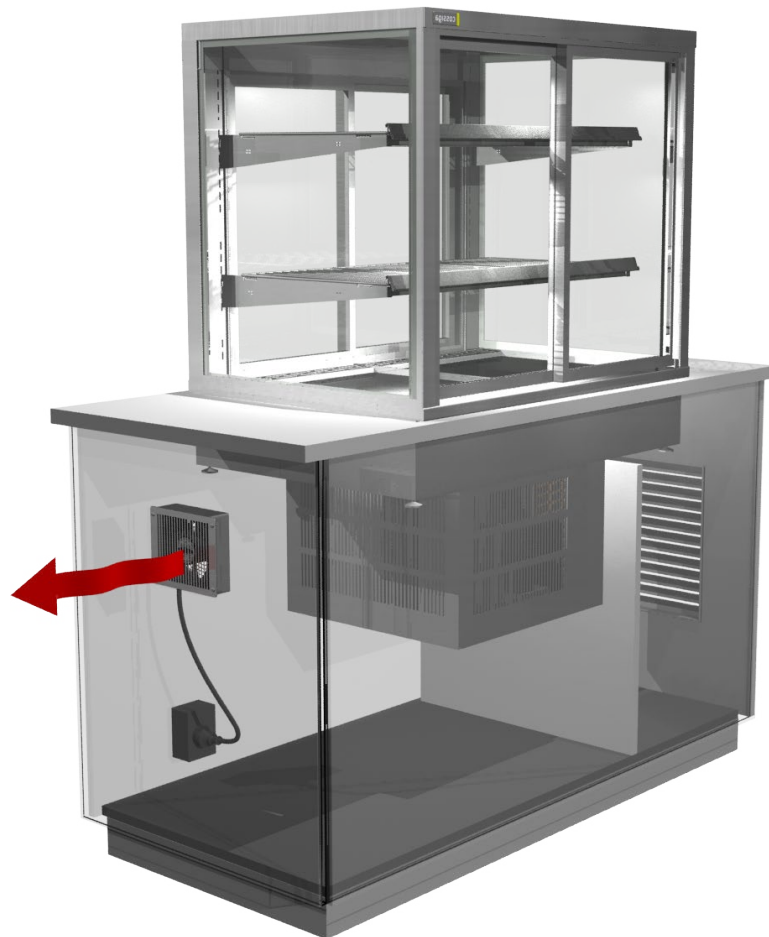

VENTILATION GRILL

- Stainless steel construction
- Hole cut out size 540 mm x 298 mm
- Square grille holes 10mm x 10mm
Cossiga part number X000765 Ventilation Grill
Screws not included
- Required minimum flow rate = $750\text{m}^3 / \text{H}$

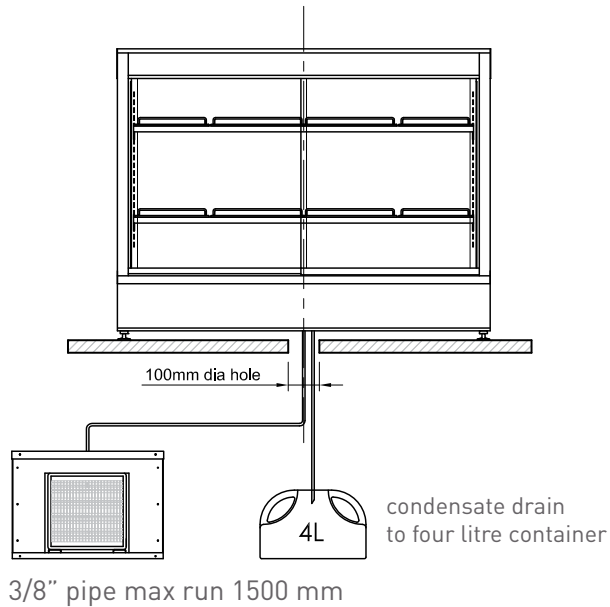

Vertical pipe runs are not recommended

- Pipe runs over 150mm :
- Expansion valve will need to be fitted
- Correctly sized condensing unit fitted
- Correct pipe size determined

REMOTE COMPRESSOR INSTALLATION

DRAINAGE RECOMMENDATIONS for high humidity locations

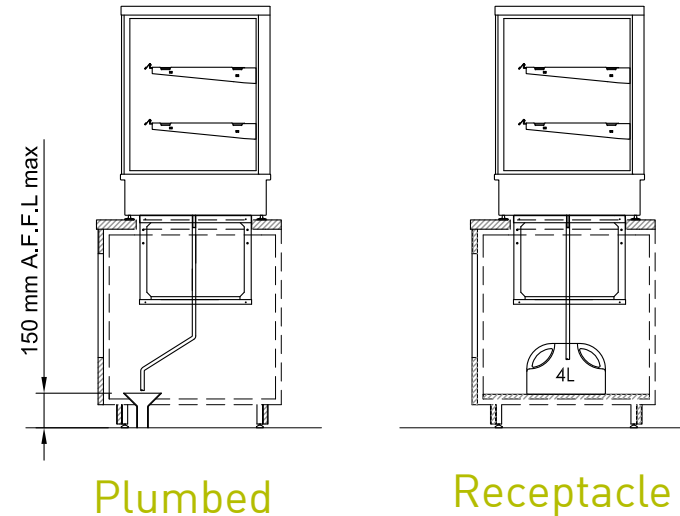

As standard units are self evaporating to a receptacle in the condenser unit. In areas of high humidity it is recommended by-passing the evaporator dish. A plastic hose can be attached to the end of the condensate drain and re-directed as shown.

PLUMBED TUNDISH DRAINAGE

- Maximum 150 mm above finished floor level
- Drainage to building waste
- Building waste by client

FREE STANDING RECIPIENT

- Receptacle placed under unit to receive condensate waste
- Dispose of waste water daily

TO BE CONSIDERED FOR HIGH HUMIDITY SITES WITH ACCESS TO DRAINAGE

THESE UNITS ARE HEAVY AND REQUIRE LIFTING INTO BENCH TOPS

PROTECT
BENCHTOP ▶

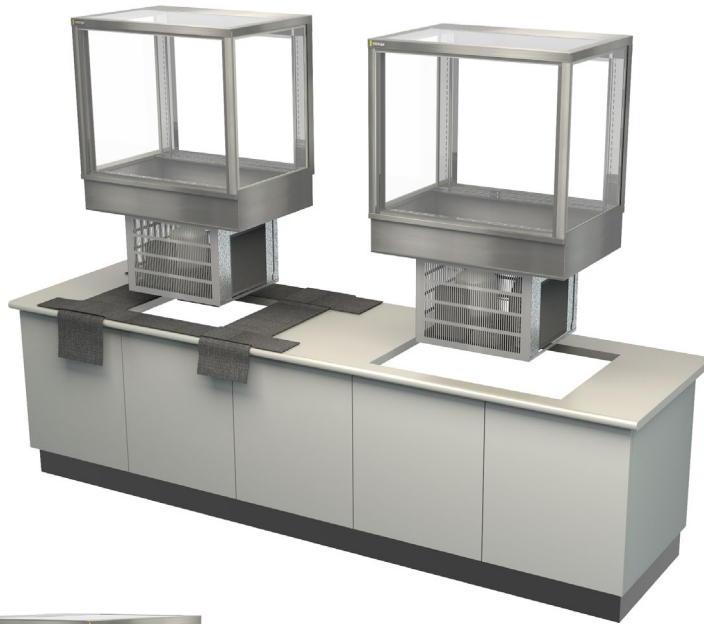

◀ REMOVE

- To reduce weight remove
- All doors
- Shelving
- Base plates

▶ PLAN AHEAD

- Have plenty of labour on hand
- Use a mechanical lifting device - optional
- Check bench top hole measurement
- Ensure enough clear depth in cabinet work
- Protect bench top with a mat or similar
- Pre-adjust unit feet if needed

All accepted local safety work wear and standards should be adhered to with a safety programme developed before undertaking of this kind of lifting work



◀ LIFT TO BENCH
AND REST

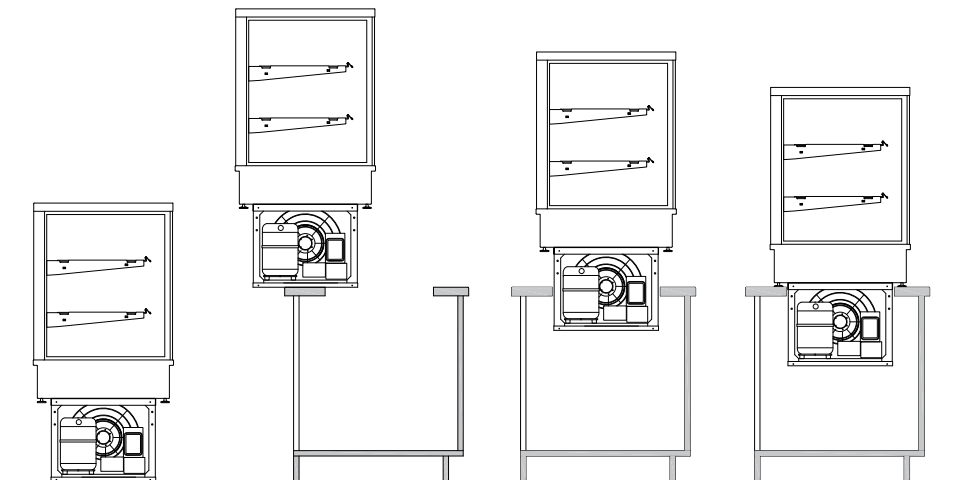

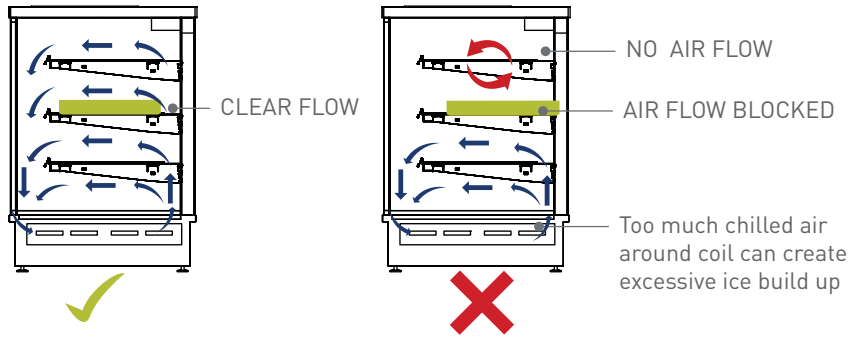

CORRECT AIRFLOW

IN CORRECT AIRFLOW

- Blocked air flow will retard operation on both HOT and COLD units
- Ensure trays or plates are not blocking air flow at rear

Locations to avoid

- Close to shop front exterior
- In an outside location
- In direct sunlight
- In a high wind
- Near any source producing excessive heat
- Service units more frequently in dusty or polluted areas

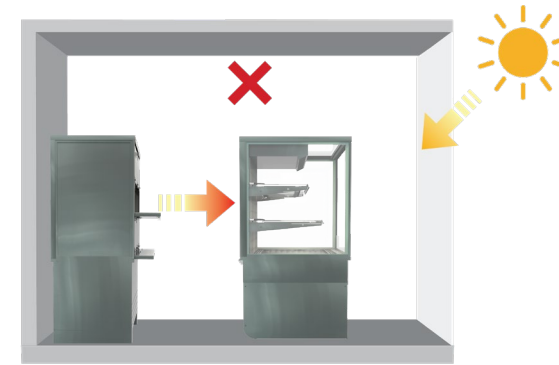

Environmental conditions

Heat from other equipment and natural conditions, such as direct sunlight straight on units, can cause cooling to fail and overload compressor

Top Mounted Controller Panel

For against wall installations
Sold individually

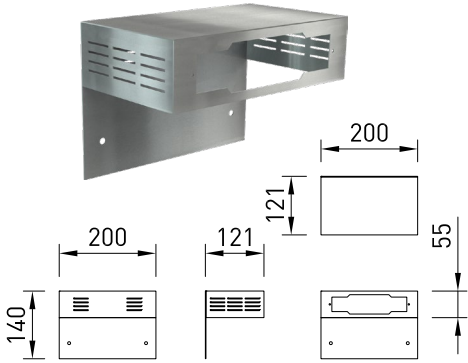

Ventilation Grill

Stainless Steel
Sold individually

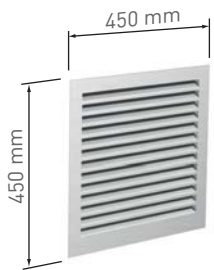

Humidity Dish

Stainless Steel
Perforated lid is removable

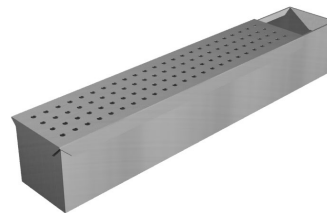

Base Tray - Heated Units

Stainless Steel
For heated units
Sold in pairs



Tong Holder

Stainless Steel
Drop into counter tray race
Sold individually



Bag Holder

Stainless Steel
Drop into counter tray race
Sold individually

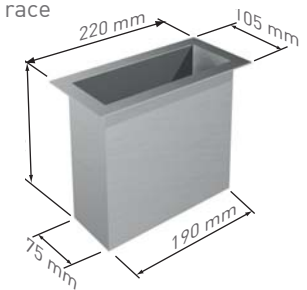



Shelf with ticket strip attached

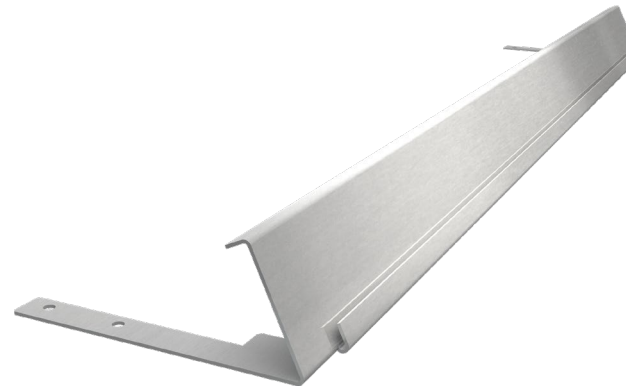

Ticket Strip
Stainless Steel
Attaches to shelf frame

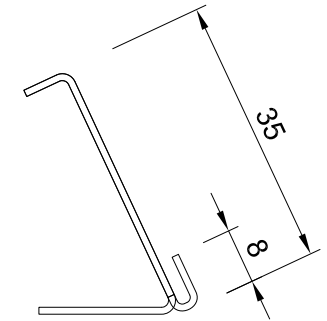

End Profile

Lengths

CABINET LENGTH MM	TICKET STRIP LENGTH
600	475
900	775
1200	1075
1500	1375

Price Tabs

Stainless Steel
Write on with marker or adhesive tape
Measure 60mm x 30mm
Sold in packs of 20



Glass Shelf Options

Standard wire racks are removed and replaced with 6mm toughened glass panes

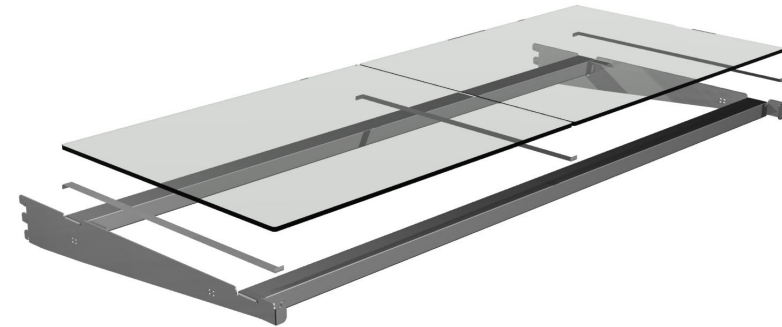
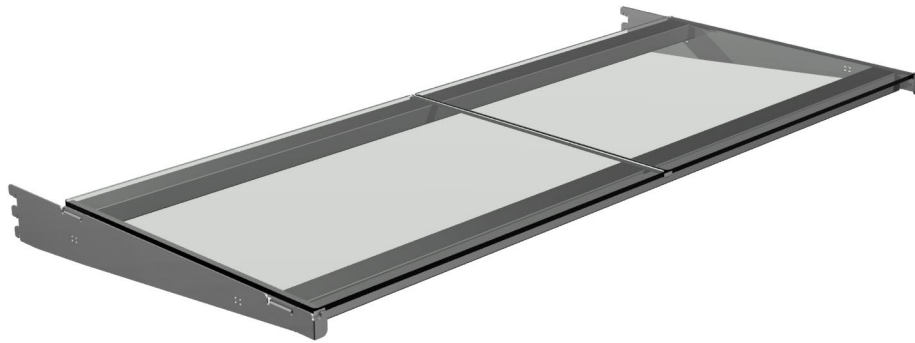

Maximum shelf load weight 15kg spread evenly

MODEL	GLASS	WIDTH MM	DEPTH MM	PER SHELF PANES	SHELVES	TOTAL PANES
STGRF6	6MM TOUGHENED - POLISHED EDGES	240	385	2	2	4
STGRF9	6MM TOUGHENED - POLISHED EDGES	390	385	2	2	4
STGRF12	6MM TOUGHENED - POLISHED EDGES	540	385	2	2	4
STGRF15	6MM TOUGHENED - POLISHED EDGES	690	385	2	2	4
STGAB6	6MM TOUGHENED - POLISHED EDGES	240	385	2	3	6
STGAB9	6MM TOUGHENED - POLISHED EDGES	390	385	2	3	6
STGAB12	6MM TOUGHENED - POLISHED EDGES	540	385	2	3	6



Support bracket

Mirror film

- Applied to the inside glass rear doors
- Suitable for heated and chilled units



ADDS
DEPTH
TO YOUR
DISPLAYS

BLOCKS
WORK AREAS
BEHIND
UNITS

Mirror film adhered to
inside of rear door glass

Pie Trays

- Stainless Steel Construction
- Placed on shelves for heated food items

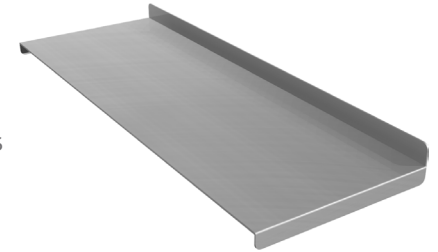

MODEL	CODE	QUANTITY	PIE TRAYS			TOTAL	TRAY WIDTH
			1ST SHELF DEPTH	2ND SHELF DEPTH	3RD SHELF DEPTH		
STGHT6	AA16015	4 Per Shelf	400MM	365MM	400MM	12 Trays	120MM
STGHT9	AA16016	6 Per Shelf	400MM	400MM	400MM	18 Trays	130MM
STGHT12	AA16017	9 Per Shelf	400MM	400MM	400MM	27 Trays	120MM

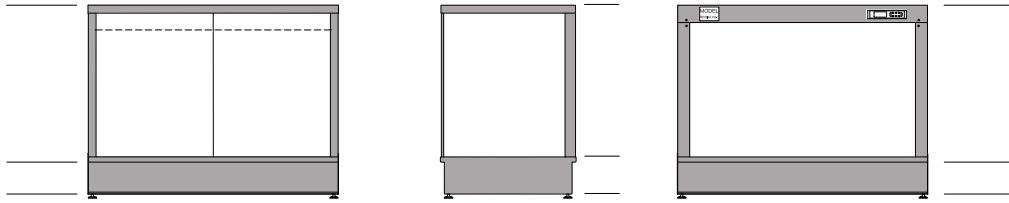

COUNTER TOP MODEL -
all exterior visible areas covered

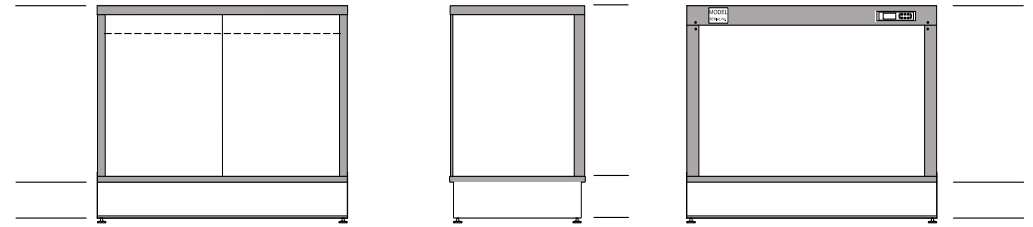

all exterior top visible areas covered

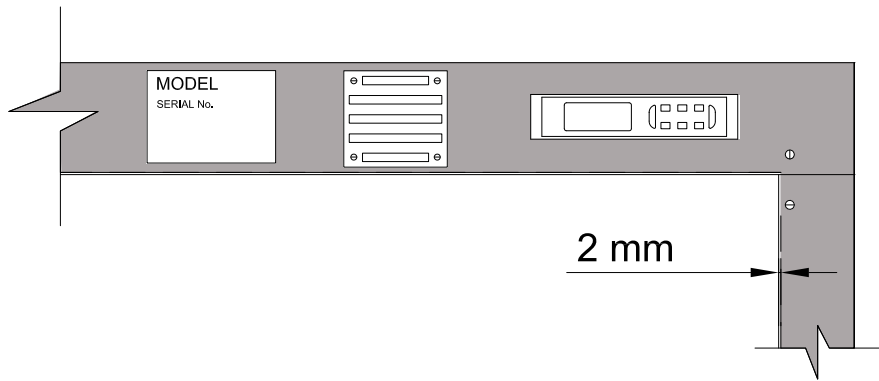

2mm gap left around rear frame

Rear of units cut around serial number plate,
exhaust fan and controller

